



BX8848 Installation Instructions

4 Diode Wiring Kit

For Motorhomes With Red Tail Lights

WARNING: Incorrect wiring may result in blown fuses, damaged wiring, fire, or bodily injury. Blue Ox recommends installation of this kit by a trained professional. Blue Ox will not be responsible for any personal property damage, or bodily injury caused by incorrect wiring or misuse of this product.

Note: Some motorhomes have amber turn signals and red brake lights which requires the use of a tail light converter to change from a 5 wire to a 4 wire system.

1. Starting in the engine compartment of the towed vehicle, run the harness through the fire wall, under the drivers side door sill plate, under the back seat, and into the trunk area. Depending on the motorhome set up, the wire at the front of the engine compartment should be wired into either a 4-wire or 6-wire trailer plug that is mounted to the front of the towed vehicle.
2. Make sure that the white wire is grounded to the vehicle chassis. It is also important to have a good ground on the towing vehicle.

Use a 12 Volt D.C. continuity lamp tester with a needle point prod to identify the "hot" wires which power the brake and tail lights. Ground one end of tester, and insert prod through the insulation of each wire to identify. At this point the 4-conductor cable should be cut to length, leaving enough slack to reach the tail light connector. **NOTE:** Vehicle lights must be on and the corresponding turn signals will have to be operating in order for wires to be "hot".

3. After the tail light and turn signal wires are identified and marked, shut off the power then cut each wire. Cut any excess wire off of the four wire harness. Leave about 6 to 8 inches of slack. Separate the four wires. Start on the outside and carefully peel each wire back about 6 inches. Cut and strip each wire and crimp a female spade terminal on each wire. Plug the green wire into the right brake diode block. Plug the yellow wire into the left brake diode block. Plug the female terminal from the front of the car into the "in" side of the tail light diode blocks and the female terminal from the rear of the car into the "out" side of the diodes. Plug the brown wire from the four wire harness into the "in" side of the diode block (see wiring diagram). Test the car tail lights to make sure they work.
4. The last part of the wiring is to ground the four wire harness. The white wire is the ground. In the engine compartment find a bolt near the wire harness that will provide a metal-to-metal contact. Carefully cut just the white wire and peel back enough wire to reach the selected bolt. Strip and crimp the ring terminal on the wire. Remove the bolt and place the ring terminal under it and tighten. **NOTE:** If you are installing a 4-wire or 6-wire trailer plug on the front of the towed vehicle, then you may insert the ground into one of these terminals to provide a ground for the system.
5. Secure the four wire harness several places between the grill and the front of dash to keep the harness from getting tangled up in moving parts or touching engine parts that will get hot.
6. Hook up the towing vehicle to the wire harness and test the installation by operating the tail lights, turn signals and brake lights. If the wiring on the towing vehicle does not match, you will need to change either the wires at trailer plug or on the towing vehicle to match.



BX8848 Installation Instructions

4 Diode Wiring Kit

For Motorhomes With Red Tail Lights

Tools Required

Electrical Tape

Wire Stripper

12 Volt DC Continuity Tester with needle point prod

Screwdriver

Terminal Crimper

Wire Cutter

Utility Knife

5' Stiff Pull Wire

Parts List

Ref. No.	Qty.	Part #	Description
1	4	294-0660	Diode Module, 6 Amp
2	1	294-0562	Wire Harness, 26', 4-Way Male
3	1	294-0187	Ring Terminal, 5/16 STD., 16-14 GA
4	12	294-0398	Terminal Coupling, Female, 22-18 GA
5	36"	194-0125	Wire, 14 GA. White

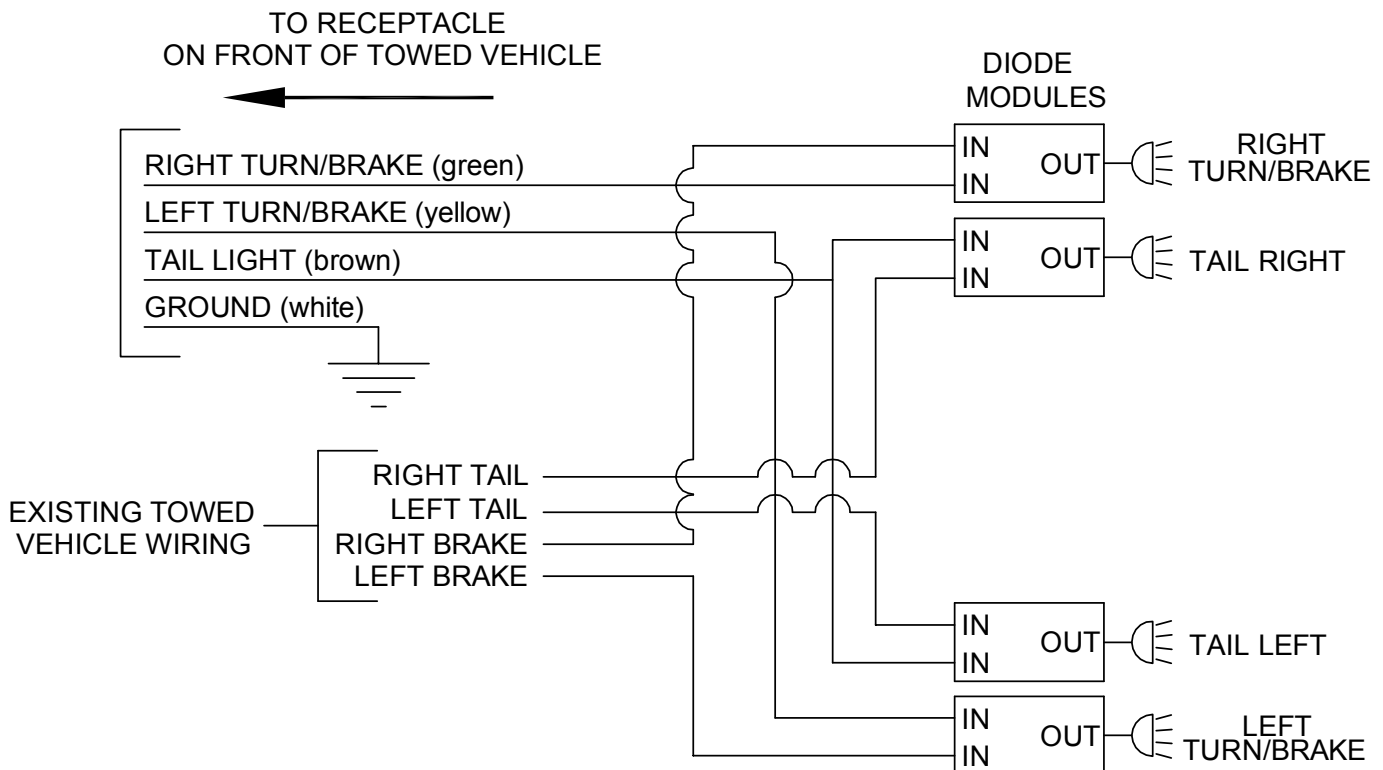



BX8848 Installation Instructions

4 Diode Wiring Kit

For Motorhomes With Red Tail Lights

Overview: Run the four wire harness from the front of the car to the back seat of the car. Identify the proper wires on the car wire harness under the back seat and splice in the diode modules. Hook the four wire harness into the diodes.

1. Decide where you want the plug of the wiring kit harness to stick out of the front of the car. This will be hooked/unhooked each time you hook/unhook your tow bar, so find a place that is convenient for you. The four wire plug will need to be cut off and the six pin trailer plug substituted. Mounts for the trailer plug are not provided. A metal bracket could be attached to the baseplate or a hole could be drilled in the bumper cover and the plug bolted into the cover.
2. On the driver's side of the fire wall there is a large rubber grommet where the main wire harness enters the passenger compartment. The wiring kit harness will also enter the passenger compartment through this grommet. The grommet is located directly behind the steering wheel and dash in the passenger compartment.
3. Route the wiring from the plug location back to the grommet in the fire wall. Be sure to keep the wire away from moving parts and areas that will get hot while the car is running.
4. Using a utility knife or a sharp pocket knife, cut a slit in the grommet just big enough to push the end of the wire through into the passenger compartment. The smaller the slit the better, so don't make it any bigger than needed.
5. Push about 12" of wire through into the passenger compartment. Locate the wire behind the dash and pull the rest of the wire through into the passenger compartment, leaving plenty of slack in the engine compartment to tie the wire harness down and still leave the plug in the desired position.
6. Along the threshold of the driver's side door there is a piece of plastic that holds the carpet down. The plastic snaps into the metal frame. Starting near the center post, pull up the plastic and unsnap it from the metal frame. The plastic narrows and continues up around the door. Do not pull this part of the plastic loose.
7. The carpet ends behind and above the brake pedal. Feed the wire harness behind the carpet and down to the threshold of the door. Pull all the wire down to this point. Lay the wire under the carpet back to the center post.
8. The bottom of the back seat is held down by two steel clips. The clips are located along the front of the seat and would be between your legs if you were sitting in the seat. Slide your finger or a small screwdriver along the seam between the seat and the floor to locate the exact position. To release the clip push in on the clip with a screwdriver. With both clips released, pull the front of the seat up and remove the seat.
9. The back door threshold is similar to the front. Pull up the threshold to gain access under the carpet. Run the wire harness around the center post (you may need a piece of stiff wire to help push the wire through) and along the back door and into the back seat area. Replace the carpet and thresholds.
10. Under the driver's side of the back seat there is a plastic loom. Open the loom and pull out the wires. You will find several light blue colored wires. Some of these wires are used for the left, right, and center brake lights. Have someone step on the brakes and use a needle point tester to determine which wires are used for the brakes. The others may be "hot" when the stereo is on, so the stereo system must be shut off while you are identifying wires.
11. When you have identified the brake wires, strip the ends and crimp on a male spade terminal on the end of the wire from the front of the car and a female spade terminal on the end running to the back of the car. Plug the male terminal into the "in" side of the diode block and the female terminal into the "out" side of the diode. Try the brakes to make sure the lights work.
12. Cut any excess wire off of the four wire harness. Leave about 6 to 8 inches of slack. Separate the four wires. Start on the outside and carefully peel each wire back about 6 inches. Inspect each wire to make sure there aren't any bare spots showing. Wrap any bare spots with electrical tape. Strip each wire and crimp a male spade terminal on each wire. Plug the white wire into the brake diode block.



BX8848 Installation Instructions

4 Diode Wiring Kit

For Motorhomes With Red Tail Lights

13. There are several brown wires in the loom. Depending on your model, 2 to 4 are used for the tail lights. Turn on the tail lights and use the needle point tester to identify the tail light wires. (Remember, stereo must be off.) When all are identified, cut the wires, strip them, and twist them together. Crimp a male spade terminal on the wires from the front of the car and a female spade terminal on the wires going to the tail lights. Plug the male terminal into the "in" side of a diode block and plug the female terminal into the "out" side of the diode block.
14. Plug the brown wire from the four wire harness into the "in" side of the diode block. Test the car tail lights to make sure they work.
15. There are multiple yellow wires in the loom. One of them is the left turn signal. Use the needle point tester to find the correct wire. When you have the correct wire, cut it, strip the ends, and put a male terminal on the wire from the front and a female terminal on the wire going to the turn light. Plug the male terminal into the "in" side of a diode block and the female terminal into the "out" side. Plug the yellow wire from the four wire harness into the remaining terminal on the diode block.
16. The dark green wire in the loom is the right turn signal. Use the needle point tester to verify that you have the correct wire. When you have the correct wire, cut it, strip the ends, and put a male terminal on the wire from the front and a female terminal on the wire going to the turn light. Plug the male terminal into the "in" side of the fourth diode block and the female terminal into the "out" side of the diode. Plug the green wire from the four wire harness into the remaining terminal on the diode block.
17. Test the turn signals to make sure they work.
18. The last part of the wiring is to ground the harness. A 36" piece of white wire has been supplied as the ground wire. In the engine compartment find a bolt that will provide a metal-to-metal contact. Strip and crimp the ring terminal on one end of the wire. Remove the bolt and place the ring terminal under it and tighten. Run the other end of the wire out to the grill by the four wire harness.
19. Using the cable ties provided, secure the four wire harness several places between the grill and the firewall to keep the harness from getting tangled up in moving parts or touching parts that will get hot.
20. The last thing to wire is the 6 pin trailer plug. If your motorhome already has a plug on it, identify which pins are what on that plug and match the wires to the pins as you wire the plug on the car. You can also go ahead and wire the plug and make adjustments for mismatched wires by switching wires where they plug into the diodes.
21. Hook up the towing vehicle to the wire harness and test the installation by operating the tail lights, turn signals, and brake lights. If the wiring on the towing vehicle does not match, you will need to change either the wires in the back seat or on the towing vehicle to match.
22. When the installation is working properly, replace as many wires as possible back into the plastic loom in the back seat. Use electrical tape to secure the rest of the wires together. Lay the diode blocks and wiring as flat as possible against the floor under the seat. Replace the rear seat. Feed all the seat belt straps and buckles through the holes in the seat as you replace it.



BX8848 Installation Instructions

4 Diode Wiring Kit

For Motorhomes With Red Tail Lights

Tools Required

Electrical Tape	Screwdriver	Wire Cutter
Wire Stripper	Terminal Crimper	Utility Knife
12 Volt DC Continuity Tester with needle point prod		5' Stiff Pull Wire

Parts List

Ref. No.	Qty.	Part #	Description
1	4	294-0660	Diode Module, 6 Amp
2	1	294-0562	Wire Harness, 26', 4-Way Male
3	1	294-0187	Ring Terminal, 5/16 STD., 16-14 GA
4	12	294-0398	Terminal Coupling, Female, 22-18 GA
5	36"	194-0125	Wire, 14 GA. White

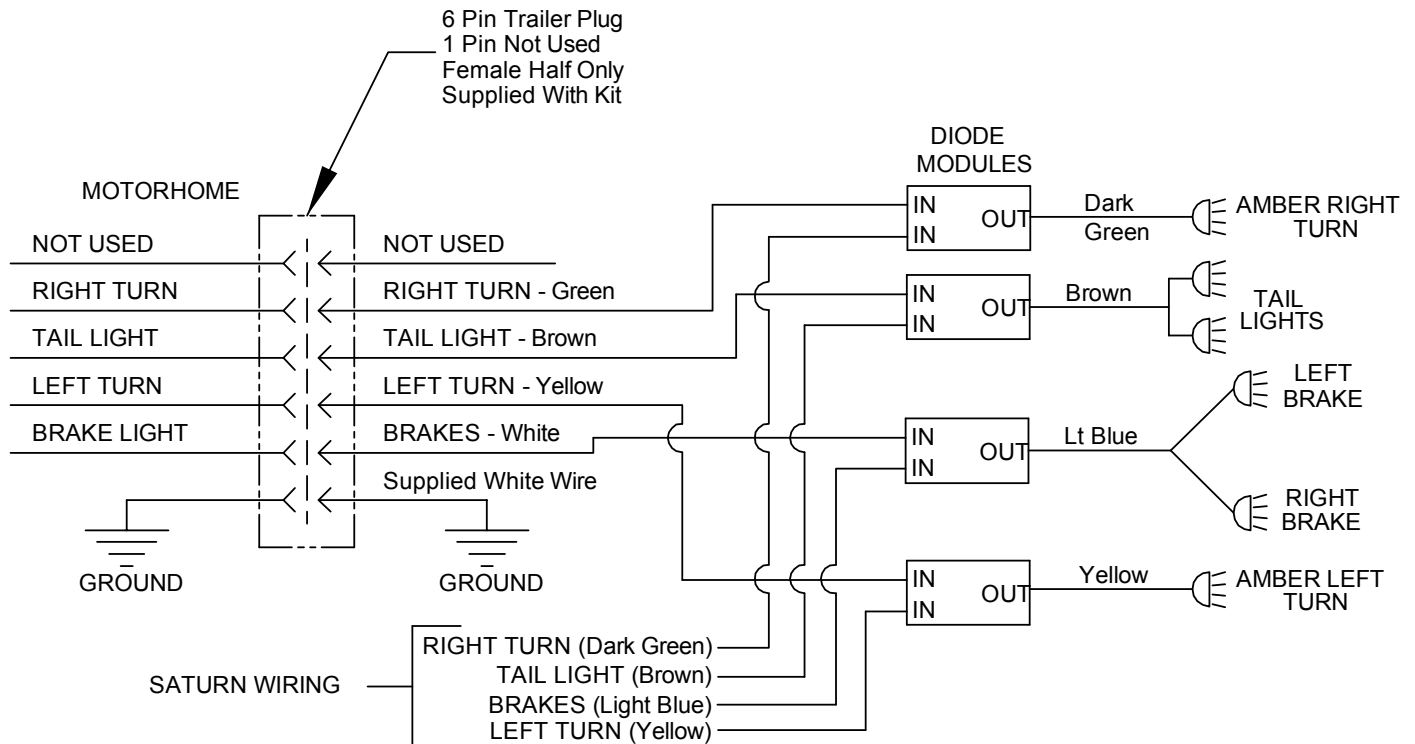

© 2012 Blue Ox
 One Mill Road, Industrial Park
 Pender, Nebraska 68047
 Phone: (402) 385-3051 • Fax: (402) 385-3360
 www.blueox.com